

## Série CTE – ED rozestup lamel 8,5 mm

Typ		16L8	23L8	34L8	45L8	51L8	68L8	84L8	90L8	125L8	158L8	209L8	254L8
Výkon $\Delta T = 8 K$	kW	1,05	1,25	2,10	2,54	3,15	3,80	4,73	5,07	7,08	9,04	11,79	14,19
Množství vzduchu	m <sup>3</sup> /h	870	780	1 740	1 560	2 610	2 340	3 270	3 120	4 900	6 530	8 180	9 810
Dofuk	m	9	8	11	10	13	12	16	14	18	20	22	24
Celková plocha	m <sup>2</sup>	3,29	4,93	6,50	9,86	9,87	14,79	14,27	19,72	21,40	28,54	35,68	42,81
Hmotnost - s ED	kg	14,80	16,40	23,60	26,40	33,40	37,80	39,30	42,70	54,20	67,40	83,50	92,90

## Společná data výparníků pro rozestup 3,5 a 8,5 mm

Ventilátory	ksxØ	1x250	1x250	2x250	2x250	3x250	3x250	2x315	4x250	3x315	4x315	5x315	6x315
Proud motorů	A	0,47	0,47	0,94	0,94	1,41	1,41	0,95	1,88	1,43	1,90	2,38	2,85
Výkon motorů	W	72	72	144	144	216	216	200	288	300	400	500	600
Kapacita okruhu	m <sup>3</sup>	1,56	2,34	2,89	4,34	4,23	6,35	6,17	8,35	8,06	11,08	13,21	17,76
Odtávání	W	750	750	1 275	1 275	1 800	1 800	2 700	2 400	3 990	5 250	6 060	7 200

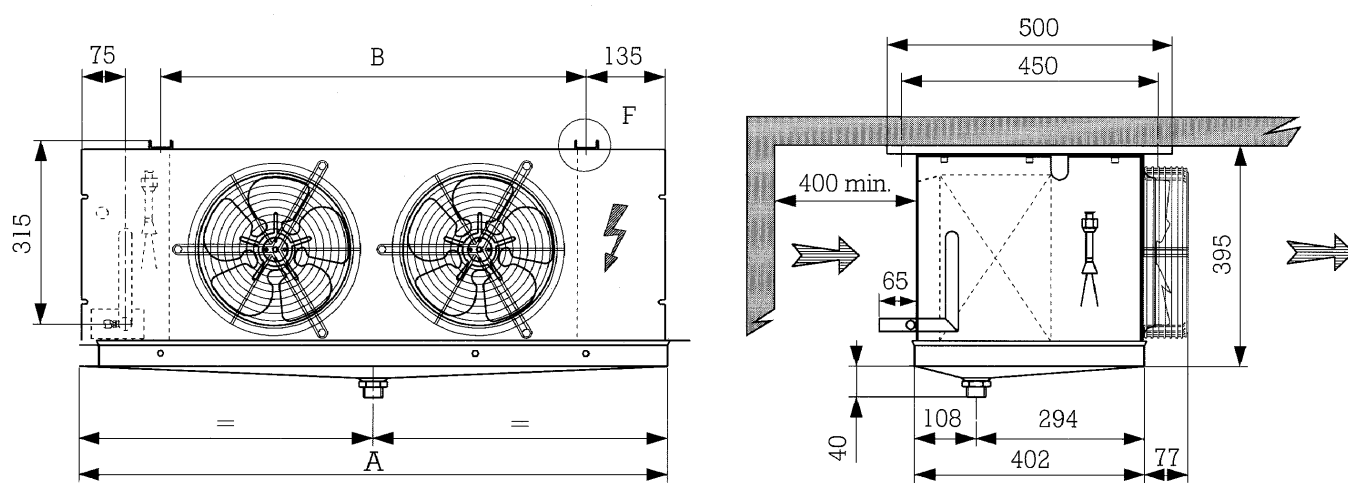

## Konstrukční charakteristiky a rozměry pro modely CTE

CTE - rozestup lamel 3,5 mm		26H - 3	53H - 3	80H - 3	-
		38H - 3	75H - 3	113H - 3	150H - 3
CTE - rozestup lamel 8,5 mm		16L - 8ED	34L - 8ED	51L - 8ED	-
		23L - 8ED	45L - 8ED	68L - 8ED	90L - 8ED
Rozměry mm	A	680	1 030	1 380	1 730
	B	380	730	1 080	1 430
Vnitřní spoj baterie	vstup	1/2" SAE	1/2" SAE	1/2" SAE	1/2" SAE
	výstup	16 mm	22 mm	22 mm	28 mm
Spoj odpadu		1" GAS	1" GAS	1" GAS	1" GAS

## Pokračování

CTE - rozestup lamel 3,5 mm		116H - 3	174 - 3	233H - 3	291H - 3	349H - 3
CTE - rozestup lamel 8,5 mm		84L - 8ED	125L - 8ED	158L - 8ED	209L - 8ED	254L - 8ED
Rozměry mm	A	1 230	1 680	2 130	2 580	3 030
	B	930	1 380	1 830	2 280	2 730
Vnitřní spoj baterie	vstup	1/2" SAE	1/2" SAE	5/8" SAE	5/8" SAE	22 mm
	výstup	28 mm	28 mm	28 mm	35 mm	35 mm
Spoj odpadu		1" GAS	1" GAS	1" GAS	1" GAS	1" GAS